

Transform your coffee game with individualMilk Technology

Introducing our Italian-designed, Swiss-made coffee machine with IndividualMilk Technology, the unique innovation offering you the ultimate experience of coffee and milk fusion. This advanced technology caters to diverse preferences, including lactose-free and vegan diets.

Discover the benefits of IndividualMilk Technology:

- Versatile milk compatibility: seamlessly adapts to various milk alternatives for consistent quality.
- Impeccable hygiene: each milk variant is meticulously prepared in separate compartments, ensuring worry-free enjoyment.

- Expanded beverage selection: craft the perfect coffee beverage, no matter the milk type.
- Custom milk foam mastery: achieve milk foam perfection with tailored texture and consistency profiles. Create authentic, high-quality foam for every beverage.

Experience the future of coffee customization with our Mytico Vario, blending innovation and craftsmanship for unparalleled coffee offerings. Elevate your customer's coffee experience with this unique innovation.



Available for Vario and Vario PrecisionFoam

Creating experiences effortlessly



1 Coffee module

- Coffee module right
- Coffee module left
- Single or double coffee spout
- Bean hopper: 2 x 1.1 kg or 4 x 0.55 kg

2 Barista module

- Steam wand Autosteam Pro S3 on the left
- Hot water spout in the center
- Traditional steam wand S1 or powder option on the right
- Barista Levers

3 Milk and cleaning system

- FoamMaster™ (FM): hot and cold milk and milk foam, individually adjustable consistency
- CleanMaster (CM): fully automatic cleaning system with integrated cleaning cartridge and cleaning tank

Mytico Vario options

- Third and fourth grinder
- Powder dosing unit
- Second steam wand as Autosteam Pro S3
- Back wall with lighting
- Coffee grounds ejection assembly
- Large bean hopper: 2 x 2.2 kg or 4 x 1.1 kg
- IndividualMilk Technology (always with 2nd UT12 cooling unit)
- PrecisionFoam (pre-configured version)

Franke Colors



The Mytico product line is not available in all markets.



Franke Kaffeemaschinen AG
cs-info.ch@franke.com

Franke Coffee Systems GmbH
cs-info.de@franke.com

Franke Coffee Systems Americas
cs-coffeesales.us@franke.com

Franke Coffee Systems UK
sales@frankecoffeesystems.co.uk

coffee.franke.com



MYTICO Vario

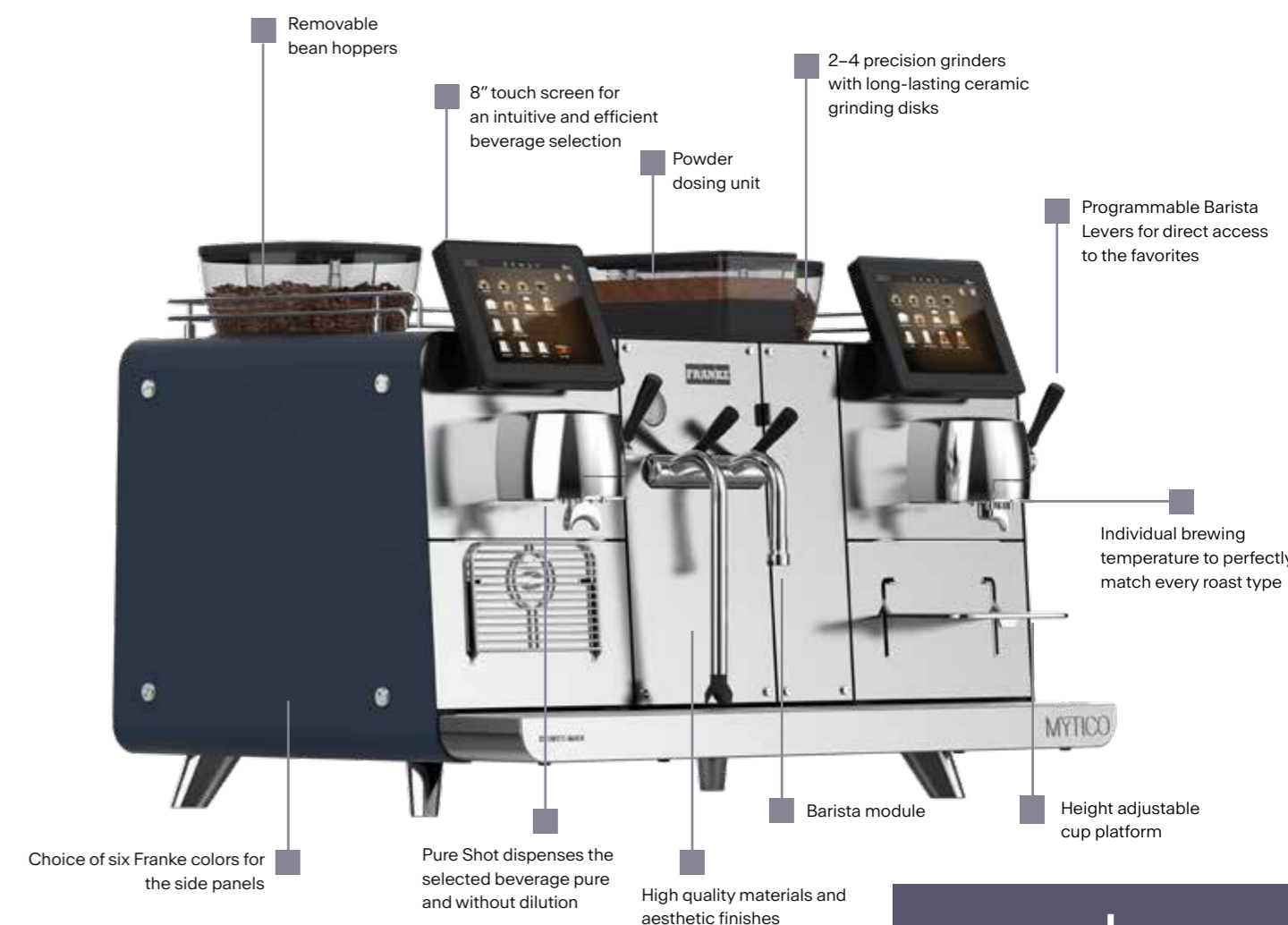

Choice of six Franke colors for the side panels

Pure Shot dispenses the selected beverage pure and without dilution

High quality materials and aesthetic finishes

Barista module

Height adjustable cup platform

Mytico Vario perfectly combines the sleek traditional Italian look with the simplicity and speed of a Franke professional automatic coffee machine. It can keep up with the best baristas and their craft without having to train skills so they can spend more time creating memorable coffee experiences with their customers. This high-performance machine makes a variety of beverages from different coffees, foams, types of milk and milk alternatives with its two intuitive touch screens.

CAPACITY*	SINGLE	PARALLEL
Espresso	190	335
Coffee	165	270
Cappuccino	190	335
Hot water	23 l/h	

*Cups per hour according to DIN 18873



Compact height
Boosts customer interaction



Design
Traditional Italian design



iQFlow™
The groundbreaking technology that extracts more flavor for unrivaled in-cup quality

590.0710.833/09.23/CH-EN/Subject to dimensional, design and version changes.

Unleash your creativity with our Barista Module

Discover the versatility of our Barista module, designed exclusively for perfecting milk-based beverages with our Italian-designed automatic coffee machine. Pour your milk or alternatives into a pitcher and choose your method: fully automatic, where air is injected into the milk for customizable foam consistency, or traditional method with steam aeration in the pitcher. Opt for our PrecisionFoam technology, dispensing milk foam at the desired consistency, temperature, and quantity, while simultaneously brewing your coffee.

At the machine's core, find a hot water spout with adjustable temperature settings for tea enthusiasts. Whether you prefer the tactile Barista Levers or the user-friendly touch screen, our Barista module guarantees ease-of-use and exceptional quality in every cup. Elevate your coffee and tea experience with Italian craftsmanship and our ultimate milk perfection tool.



Technical data

Machine	
Model	Vario
Power	380–415 V 3LNPE 16 A, 50/60 Hz, 4.6–9.0kW
Dimensions	925 mm/610 mm/644 mm (W/H/D)
Weight (empty)	approx. 105 kg
Franke Colors	Onyx, Cotton, Sand, Burgundy, Blueberry, Basil
Cleaning System	CleanMaster

Water connection	
Water connection	Metal hose with union nut G3/8", L = 1500 mm
Water supply line	If possible on installation side: untreated water of drinking water quality (not from household decalcification system)
Water pressure	80–800 kPa (0.8–8.0 bar)
Flowrate	>0.1 l/sec
Water temperature	<25°C
Total hardness	4–8°dH GH (German total hardness)/ 7–14°fH GH (French total hardness)/ 70–140 ppm (mg/l)
Carbonate hardness	3–6°dH KH (carbonate hardness)/ 50–105 ppm (mg/l)
Acid content/pH value	6.5–7.5 pH
Chlorine content	<0.5 mg/l

Water drain	
Drain hose	Diam.= 19 mm, L = 2000 mm

Add-On Units	
Cooling unit	UT12 CM (12 l)
Electrical connection	220–240 V 1LNPE 50/60 Hz 0.72 A (10 A) 110–127 V 1LNPE 60 Hz 1.5–1.7 A (10 A) 220 V 1LNPE 50 Hz 0.72 A (10 A) 100 V 1LNPE 50/60 Hz 1.7 A (10 A)
Dimensions	340 mm/540 mm/475 mm (W/H/D)
Weight (empty)	approx. 26 kg
Colors	anthracite

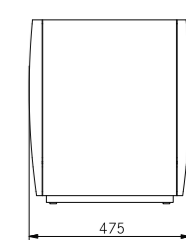
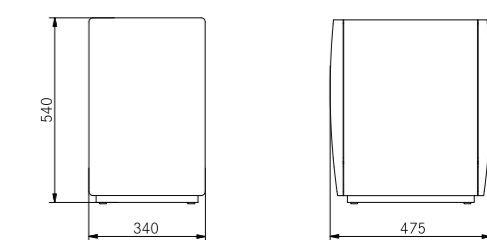
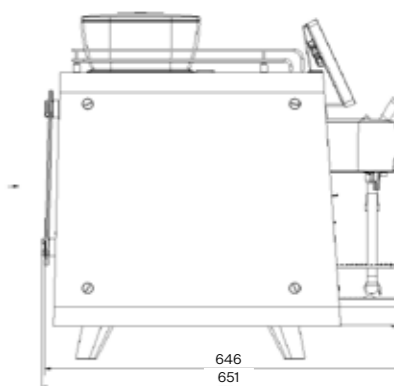
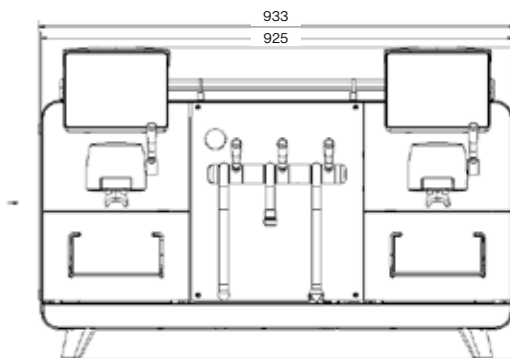

Barista module for Vario



S3-H1-S1
Pos. 1: Autosteam Pro S3
Pos. 2: Hot water spout
Pos. 3: Traditional Steam S1



S3-H1-S3
Pos. 1: Autosteam Pro S3
Pos. 2: Hot water spout
Pos. 3: Autosteam Pro S3



w. Powder S3-H1-P1
Pos. 1: Autosteam Pro S3
Pos. 2: Hot water spout
Pos. 3: Access door to mixing-chamber

Barista module for Vario PrecisionFoam



PF-S3-PF
Pos. 1: PrecisionFoam
Pos. 2: Autosteam Pro S3
Pos. 3: PrecisionFoam



PF-H1-PF
Pos. 1: PrecisionFoam
Pos. 2: Hot water spout
Pos. 3: PrecisionFoam



PF-H1-P1
Pos. 1: PrecisionFoam
Pos. 2: Hot water spout
Pos. 3: Access door mixing-chamber